

Product Information

Door closing force measurement **DC360NBT** with HGE - DataManager software

According to: BS EN 14752:2005, GOST 14752:2005, ABNT NBR 14752:2005, UNE-EN 14752:2005, American RAIL STANDARD APTA PR-M-S-18-10



Content

Door closing force measurement device	1
HGE-DataManager ©	3
HGE-Viewer ©	4
HGE -Special measurement 1	5
HGE -Special measurement 2	6
Product overview/Technical data	7
Measurement rods DIN/BS EN 14752 / VDV 111/ VDV 157	8
Other products	8

Version 09/24

Door closing force measurement device type DC360NBT

The door closing force measuring device type DC360NBT is an outstanding instrument for the measurement and evaluation of the closing force of railway-, tram- and bus doors. The measuring device was constructed according to DIN EN 14752:2005 / BS EN 14752:2005 and VDV 111/VDV 157.

Optionally a special measurement for doors of vehicles with repeating closing process is available - based on DIN/BS EN 14752:2005. The door closing force measuring device type DC360NBT therefore corresponds to all requirements placed on the measurement of door closing forces. Due to a simple operation and to precise measured values the review process is implemented quickly and uncomplicated.

The door closing force measuring device meets the highest measuring accuracy and handling standards by the use of innovative materials and components.

The housing of the load cell has been made of special plastic which offers weight savings, high resistance to environmental factors and maximum impact resistance. High-quality, durable controls with very low friction resistance have been installed inside the load cell. The door closing force measurement device therefore has a high measuring accuracy with a discrepancy of $\pm 3\%$ of the measured value at the range from 50 up to 360N.

The handheld computer Zebra TC-21 is supplied with a bag and shoulder strap for ergonomic working. The user is enabled to have the other hand free during measuring.

In addition, our concept offers the advantage of the handheld computer TC-21 by being combinable with our 700NBT measuring device. In order to reduce costs.



The measuring process is realized fast and uncomplicated. The measured data are recorded immediately and are displayed visually by our handheld computer Zebra TC-21 device.

The menu guidance of the handheld computer has consciously been kept simple in order to allow the user a fast and simple operation.

The user has the choice of several inputs: job number/vehicle number, running performance (mileage) of the vehicle, notes, signature (touch screen), number of doors, door name (4 digits, alphanumeric) and door type with the corresponding limit values and measuring points.

The measuring process provides information about the measured peak force and effective force. If the preset limit value is exceeded, this will be brought to the user's attention - both visually and acoustically. The door overview provides the user with an immediate overview of the status of the doors to be measured and those already measured. A tick is displayed if the door is ok. A red cross appears if a limit value has been exceeded.

An advantage of our software is that a measuring process that has been started can be interrupted and restarted later.

This enables the user to flexibly organize his work and time.

The handheld computer Zebra TC-21 provides storage capacity for more than 1.000 vehicle measurements of 32 doors with max. 3 measuring points (3 measurements per measuring point).

At the end of each measuring process a detailed measuring log is created which can be retrieved immediately on the handheld computer and can be transferred to a PC in PDF and Excel format.

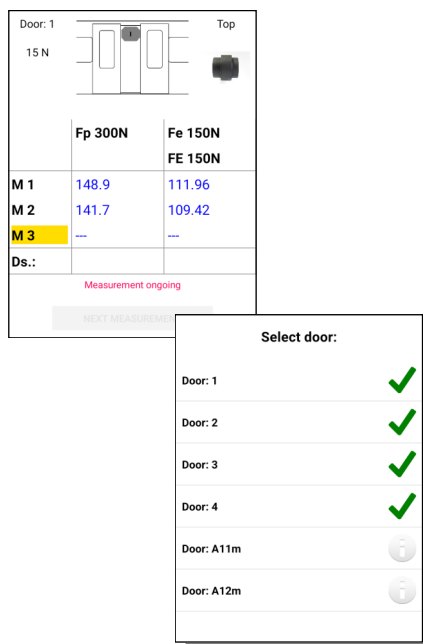
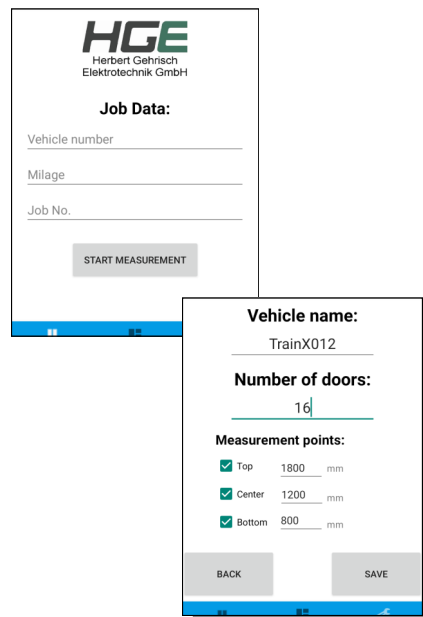

HGE Messprotokoll Türschliebkraftmessung (alle Längen in mm)																		
Fahrzeug-Nr.	Auftrags-Nr.	S-Nr.	Standort	Datum	Uhrzeit	Prüfer												
784	45455	18119	0	19.06.2010	13:20:01	Schnee												
Fahrzeug-Bemerkung: 164445							Fahrzeug-Status: In Ordnung											
Grenzweite in N:							Fp(50)	400	Fp(100)	300	Fp(200)	300	Fp(300)	400	Fp(500)	4000	Fp(x)	400
Tür-Nr. 1:																		
Türmessung:																		
50mm 100mm 200mm 300mm 500mm custom mm																		
Messung 1: 188.33 142.01 135.42 123.41 112.44 97.74 Kraft Fp																		
0.41 0.50 0.28 0.50 0.31 0.50 0.26 0.50 0.20 0.50 0.19 0.50 0.21 0.51 Mess rRes																		
112.42 115.15 111.93 119.97 105.26 105.65 Kraft Fp																		
Messung 2: 0.27 0.50 0.24 0.50 0.20 0.50 0.22 0.50 0.19 0.50 0.21 0.51 Mess rRes																		
112.25 98.98 112.30 128.73 122.20 107.99 Kraft Fp																		
Messung 3: 0.22 0.50 0.13 0.50 0.23 0.50 0.23 0.50 0.27 0.50 0.17 0.52 Mess rRes																		
Durchschnitt: 188.33 142.01 135.42 123.41 112.44 97.74																		
Tür-Status: i.O.																		
Tür-Nr. 2:																		
Türmessung:																		
50mm 100mm 200mm 300mm 500mm custom mm																		
Messung 1: 113.32 97.39 101.91 103.89 99.89 107.43 Kraft Fp																		
0.25 0.50 0.19 0.50 0.20 0.50 0.24 0.50 0.21 0.51 0.15 0.50 Mess rRes																		
104.77 97.89 99.84 99.80 91.67 79.04 Kraft Fp																		
Messung 2: 0.21 0.50 0.22 0.51 0.20 0.51 0.22 0.51 0.21 0.50 0.20 0.50 Mess rRes																		
90.50 73.86 71.27 89.82 97.19 86.72 Kraft Fp																		
Messung 3: 0.20 0.50 0.14 0.51 0.13 0.51 0.23 0.53 0.14 0.50 0.20 0.50 Mess rRes																		
Durchschnitt: 113.32 97.39 101.91 103.89 99.89 107.43																		
Tür-Status: i.O.																		

Complete view of the measuring log on the handheld computer Zebra TC-21

HGE-DataManager ©

The **HGE-DataManager** © software for the door closing force measuring device offers a simple and fast data transfer from the handheld computer Zebra TC-21 to the user's PC. A choice of several formats is available for storing the measured data (PDF and EXCEL).

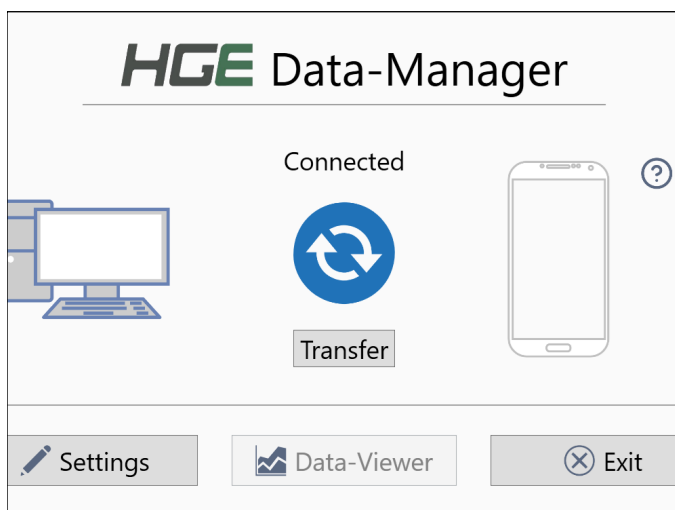

Settings, choice of several formats

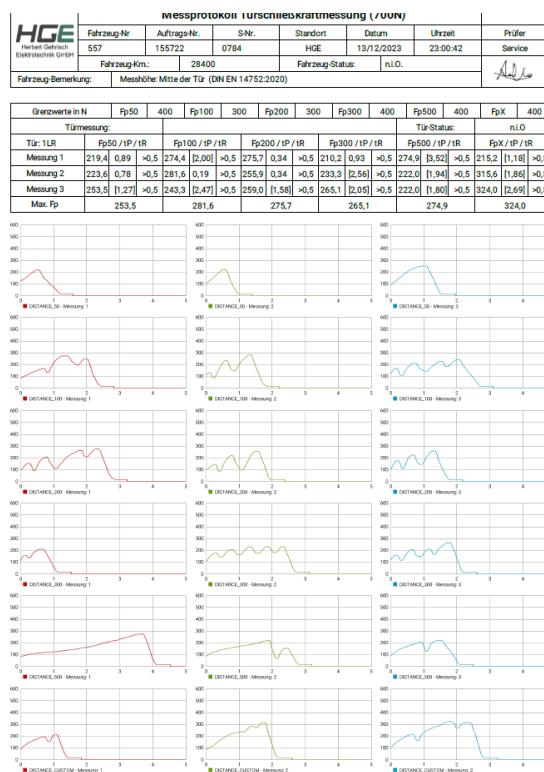

View of measurement log of PDF-Format

The **HGE-DataManager** © software also provides the user with additional information on the current status of the rechargeable battery and the remaining storage capacity of the handheld computer Zebra TC-21.

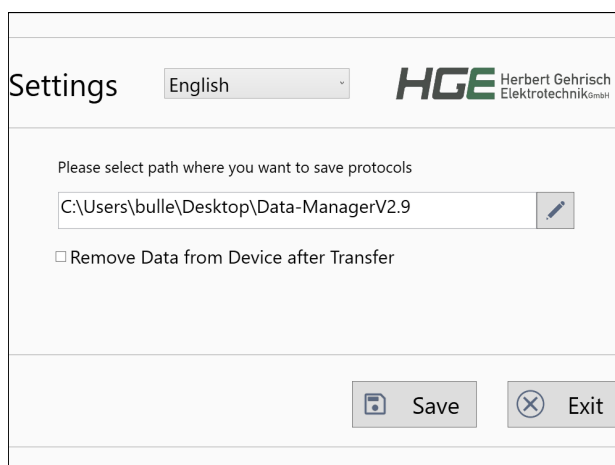

User interface of **HGE-DataManager** ©

HGE-Viewer ©

The **HGE-Viewer** © is part of the **HGE-DataManager** ©. It enables the user to represent the measured data recorded in detail in diagrams. The measurement curves can be studied and analyzed precisely.

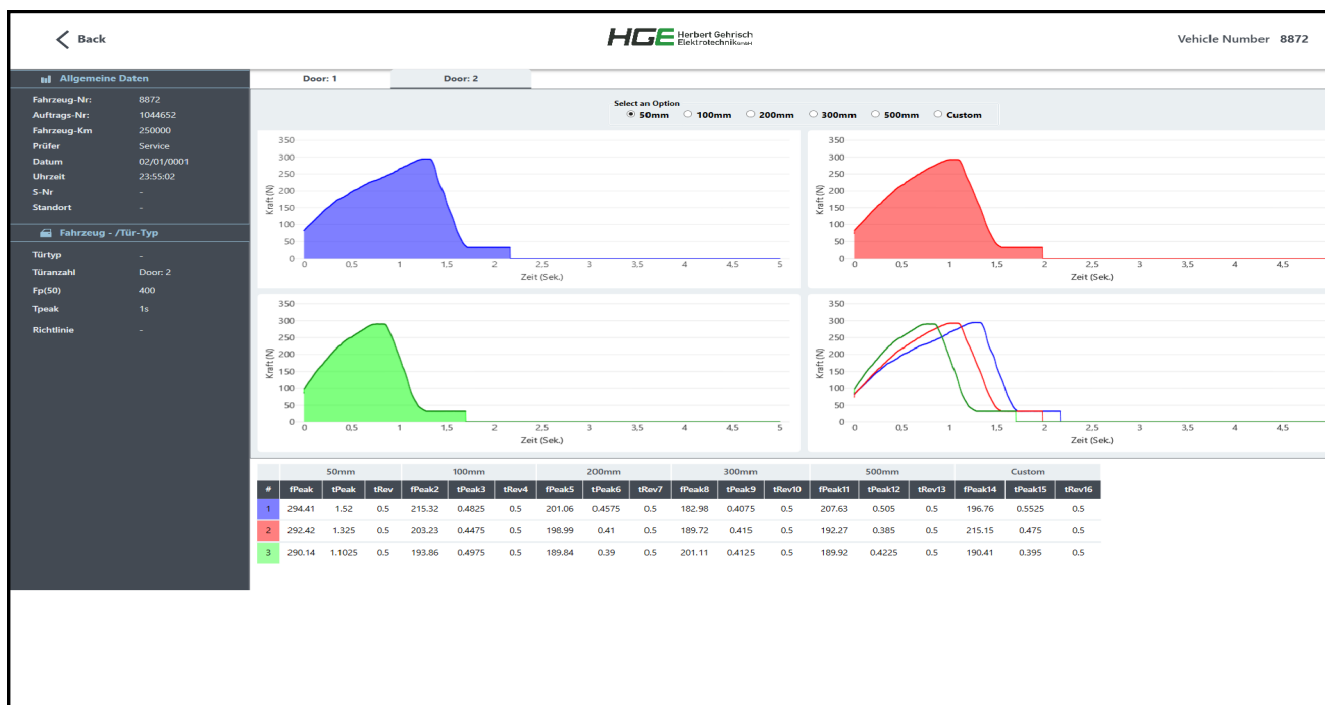

HGE - Special measurement

- for doors with temporary force impulse at the beginning of closing process

Special measurement with a temporary force impulse (Overriding– and dropping below the minimum force height of 50N) at the beginning of closing process - according to DIN/BS EN 14752.

The special measurement allows a door closing measurement in which the lower deviation of the 50N limit will not be taken into consideration regarding the variable time periode t_x . The initial force impulse e.g. caused by a rubber edge of the door, does not lead to an abort of measurement.

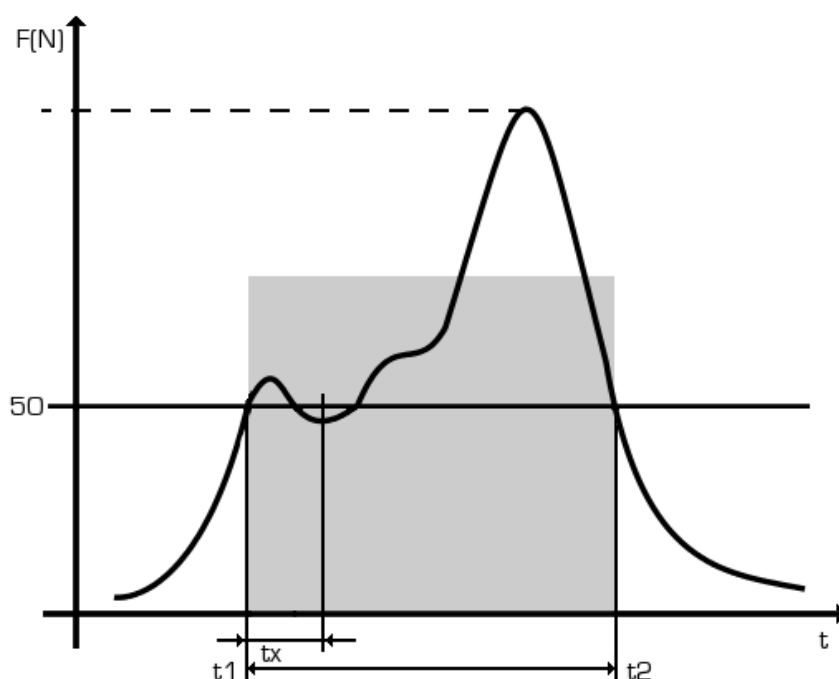

Figure: Force impulse at the beginning of a closing process

This special measurement based on DIN/BS EN 14752 can be selected in the menu of the handheld computer Zebra ZC 21 software and can be assigned to the appropriate type of vehicle/door. In the vehicle remarks of the metrology record additionally "Special measurement" is registered.

Product overview:



Load cell	
Load cell material:	Glass fiber-reinforced plastic / aluminium
Weight of the load cell:	Approx. 1.4 kg
Measuring range:	30 to 360N (Optional 500N)
Measuring accuracy:	± 3% of measuring value at the range from 50 to 360N
Spring Stiffness (compression spring):	10 ± 0,2 N/mm
Diameter:	100 mm
Gap width:	115 mm
Dimensions:	115 mm x 126 mm x 288 mm
Operating temperature range:	+ 10°C to + 30°C
Handheld Computer	
Operating time:	Without charging the battery in normal operation approx. 8 hours
Weight:	Approx. 455 g
Memory:	32 GB
Display:	Colour-Touchscreen Display
Protection class IP 65 – can withstand multiple drops onto smooth concrete surfaces from 1.5 meters - with a protective bag with Shoulderbelt and belt clip.	



HGE-Door closing force measurement device with case

Weight approx. 7 Kg, Guarantee 2 Years

Scope of delivery:

- Handheld computer TC-21 including Battery and protection bag
- Load cell DC3600NBT, Special measurement mode
- 1 Tabletop station/docking station with A/C-adapter for charging the battery as well as for data transfer
- 1 USB transfer cable from tabletop station to the PC
- "Door closing force measurement device" user manual
- Enclosed sheet: "Administrator Information"
- Installation USB Stick with the HGE DataManager software
- Company calibration document
- Other Accessories

Set of measurement rods DIN/BS EN 14752:2005/2020 and VDV 111/ VDV 157 inclusive spring balance with calibrating service



Measurement rods according to DIN EN 14752 and VDV 111 / VDV 157 o meet the requirements in the test sequence of closing force measurement.

- Measurement rod 1 to review the pinch protection on doors (10mm x 50mm x 300mm)
- Measurement rod 2 to review the pinch protection on doors (30mm x 60mm x 300mm)
- Measurement rod 3 to review the trapping detection on doors
- Spring balance, measuring range up to 200N
- Measurement rod 4 for verification of power-operated Steps (150 N)
- Measurement rod 5 „Testing of area monitoring system“ according DIN EN 4752:2020, diameter 8 mm, length 300 mm, radiance 2% - 5% / > 90%



Case with measurement rods 1 to 5 with spring balance

Further products :

HGE-Door closing force measurement device DC700N BT

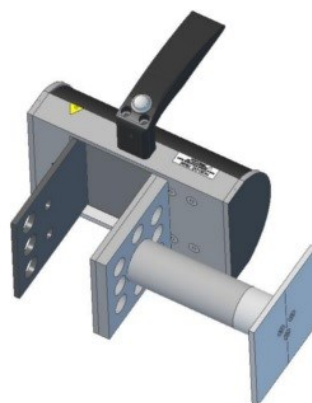

According to: **British Standard EN 14752:2015, European Standard EN 14752:2020**

- Measuring range: **50 N to 700 N**
Force level 1: Standard doors (Max. 400 N)
Force level 2: for high traffic density (Max 600 N)
- Measuring accuracy:
Forces up to 100 N: **± 3 N**
Forces higher than 100N: **± 3 %** from value
- Spacer for different doorways with quick-release mechanism for quick adaption (opening width: 50, 100, 200, 300, 500 mm and on requirement)
- Display of peak force (Fp), duration of closing procedure (tpeak) and lag of the door's reversing (trev).
Optical and acoustic signals if critical value is exceeded
- Special measurement for doors with an temporary force impulse at the beginning of closing process;
- Simplified serial measurement possible



HGE-Door closing force measurement device with case

Weight approx. 10 Kg, Guarantee 2 Years

Scope of delivery:

- Handheld computer TC-21 including Battery, 32 GB memory and protection bag
- Load cell DC700NBT, Special measurement mode
- Spacer for different doorways according to EN 14752:2015
- 1 Tabletop station/docking station with A/C-adapter for charging the battery as well as for data transfer
- 1 USB transfer cable from tabletop station to the PC
- "Door closing force measurement device" user manual
- Installation USB Stick with the HGE DataManager software
- Company calibration document
- Other Accessories



Herbert Gehrish Elektrotechnik GmbH
Nibelungenstraße 784
D-64686 Lautertal

Tel.: +49 (0)6254 7025
Fax: +49 (0)6254 37297
E-Mail: info@gehrisch.de
Web: www.gehrisch.de

For this document and the objects represented we reserve all rights. Use of its contents is prohibited without our explicit consent. Subject to change. Liability for incorrect, incomplete or outdated information is excluded.
